

brother

TWIN NEEDLE, NEEDLE FEED LOCK STITCHER MACHINE

DOPPELNADEL-VERRIEGELUNGSSTICHMASCHINE MIT NADELTRANSPORT

MACHINE À DOUBLE AIGUILLE POUR POINT D'ARRÊT AVEC ENTRAÎNEMENT PAR AIGUILLES

MÁQUINA DE DOBLE PESPUNTE CON TRANSPORTE DE AGUJA Y DOS AGUJAS

LT2-B831

PARTS BOOK

TEILEKATALOG

LIVRE DES PIÈCES

LIBRO DE REFERENCIA DE PIEZAS

P831302

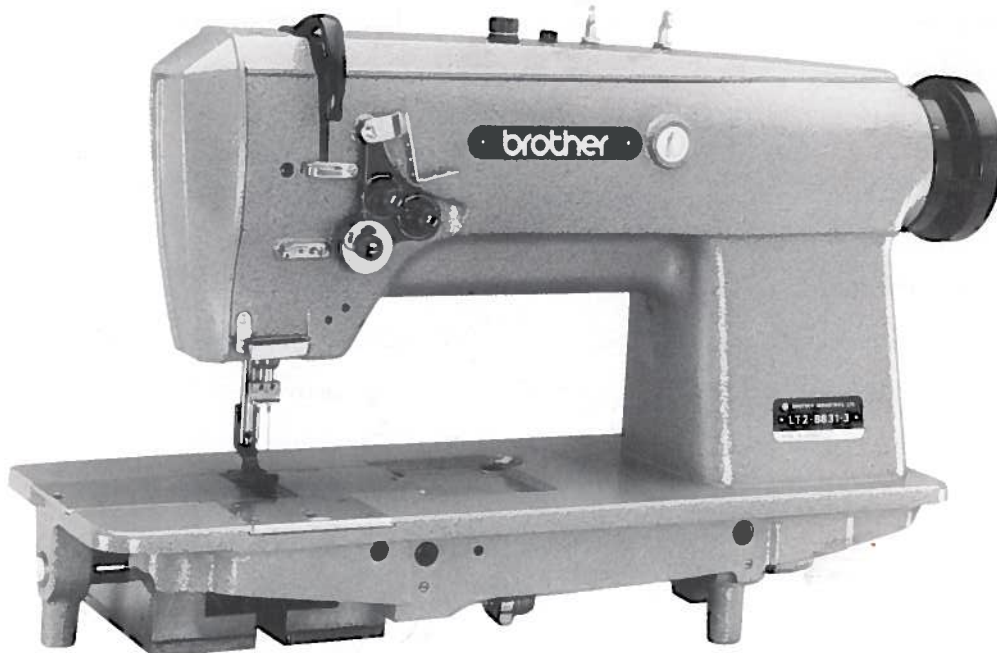

Notes for using this parts book

1. This book is applicable to sewing machines which have the same plate number as shown on the cover of this book (or correction sheet).
2. The symbol  in the "Parts No." column indicates that the parts is not available for supply. If, however, there is a number in the "Assembly No." column, the parts can be ordered as an assembly. Please, therefore, order by using the Assembly No.
3. This book was prepared based on information available in October, 1983.
4. Parts are subject to changes in design without prior notice.

Anmerkungen zum Gebrauch dieses Stücklistebuches

1. Dieses Buch bezieht sich auf die Nähmaschinen mit derselben Kennungsnummer wie auf diesem Buchumschlag (oder auf dem Korrekturblatt).
2. Dieses Zeichen  in der Spalte "Teilnummer" bedeutet, daß dieser Teil nicht lieferbar ist. Wenn jedoch in der Spalte "Gerätesatznummer" eine Nummer steht, kann dieser Teil als ein Geräteteilsatz bestellt werden. Bestellen Sie daher bitte mit dieser Gerätesatznummer.
3. Dieses Buch basiert auf den Informationen vom Oktober, 1983.
4. Modelländerungen sind vorbehalten.

CONTENTS

A. Machines body	1
B. Threading mechanism	2
C. Upper shaft mechanism	3
D. Feed shaft mechanism	4
E. Needle bar racking mechanism	5
F. Presser foot mechanism	6
G. Gauge parts mechanism	7
H. Rotary hook mechanism	8
J. Lower shaft mechanism	9
K. Lubrication (1)	10
K. Lubrication (2)	11
Z. Accessories (1)	12
Z. Accessories (2)	13
Gauge parts list	7
INDEX	14

INHALTSVERZEICHNIS

A. Maschinengehäuse	1
B. Fadenführungsvorrichtung	2
C. Obere Welle	3
D. Transport welle	4
E. Nadelstangenbetätigung	5
F. Stoffdrückerfuß	6
G. Lehren	7
H. Greifervorrichtung	8
J. Untere welle	9
K. Schmierung (1)	10
K. Schmierung (2)	11
Z. Zubehör (1)	12
Z. Zubehör (2)	13
Lehren liste	7
VERZEICHNIS	14

Notes sur l'utilisation de ce manuel de pièces détachées

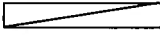
1. Ce manuel est destiné aux machines à coudre ayant le même numéro de plaque montré sur la couverture de ce manuel (ou sur la feuille de corrections).
2. Le symbole  dans la colonne "N° de pièce" signifie que la pièce ne peut être fournie. Si, dans la colonne "N° jeu de pces", il y a un numéro de nomenclature, la pièce peut être commandée comme faisant partie d'un jeu de pièces. Donc, pour toute commande, veuillez spécifier le N° du jeu de pièces.
3. Ce manuel a été fait d'après les renseignements valables au mois de Octobre 1983.
4. Les pièces peuvent être sujettes à des modifications sans préavis.

Notas para usar este Libro de Piezas

1. Este libro sirve para todas las máquinas de coser que llevan la misma placa de identificación que la se puede ver en la tapa de este libro (o en la hoja de erratas).
2. El símbolo  , que se encuentra en la columna del "Número de Pieza", quiere decir que no se dispone de dicha pieza sola. Cuando, empero, hay un número en la columna del "Número de Juego", se podrá ordenar la pieza con todo el juego. Por lo tanto, será mejor hacer el pedido recurriendo al número del juego respectivo.
3. Este libro ha sido compilado basándose en los datos de que se disponía en octubre de 1983.
4. Las piezas quedan sujetas a cambios de diseño sin aviso previo.

TABLE DES MATIERES

A.	Corps de la machines	1
B.	Mécanisme de Jénfilage	2
C.	Mécanisme de l'arbre superieur	3
D.	Mécanisme de l'arbre entraînement	4
E.	Mécanisme de balancement de la barre á aiguille	5
F.	Mécanisme du pied presseur	6
G.	Pièces d'écartement	7
H.	Mécanisme du crachet rotatif	8
J.	Mécanisme de l'arbre infrieur	9
K.	Lubrification (1)	10
K.	Lubrification (2)	11
Z.	Accessoires (1)	12
Z.	Accessoires (2)	13
	Liste des pièces d'écartement	7
	INDEX	14

INDICE

A.	Denominación del mecanismo	1
B.	Mécanisme de la enhebrado	2
C.	Mécanisme de la eje superior	3
D.	Mécanisme de la eje alimentación	4
E.	Mécanisme de ascilación de la barra de aguja	5
F.	Mécanisme del prensa telas	6
G.	Piezas calibradoras	7
H.	Mécanisme del cangrejo	8
J.	Mécanisme de la eje inferior	9
K.	Lubricación (1)	10
K.	Lubricación (2)	11
Z.	Accesorios (1)	12
Z.	Accesorios (2)	13
	Lista de piezas calibradoras	7
	INDICE	14

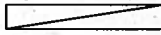
A. Machine body / Maschinengehäuse
 Corps de la machine / Denominación del mecanismo

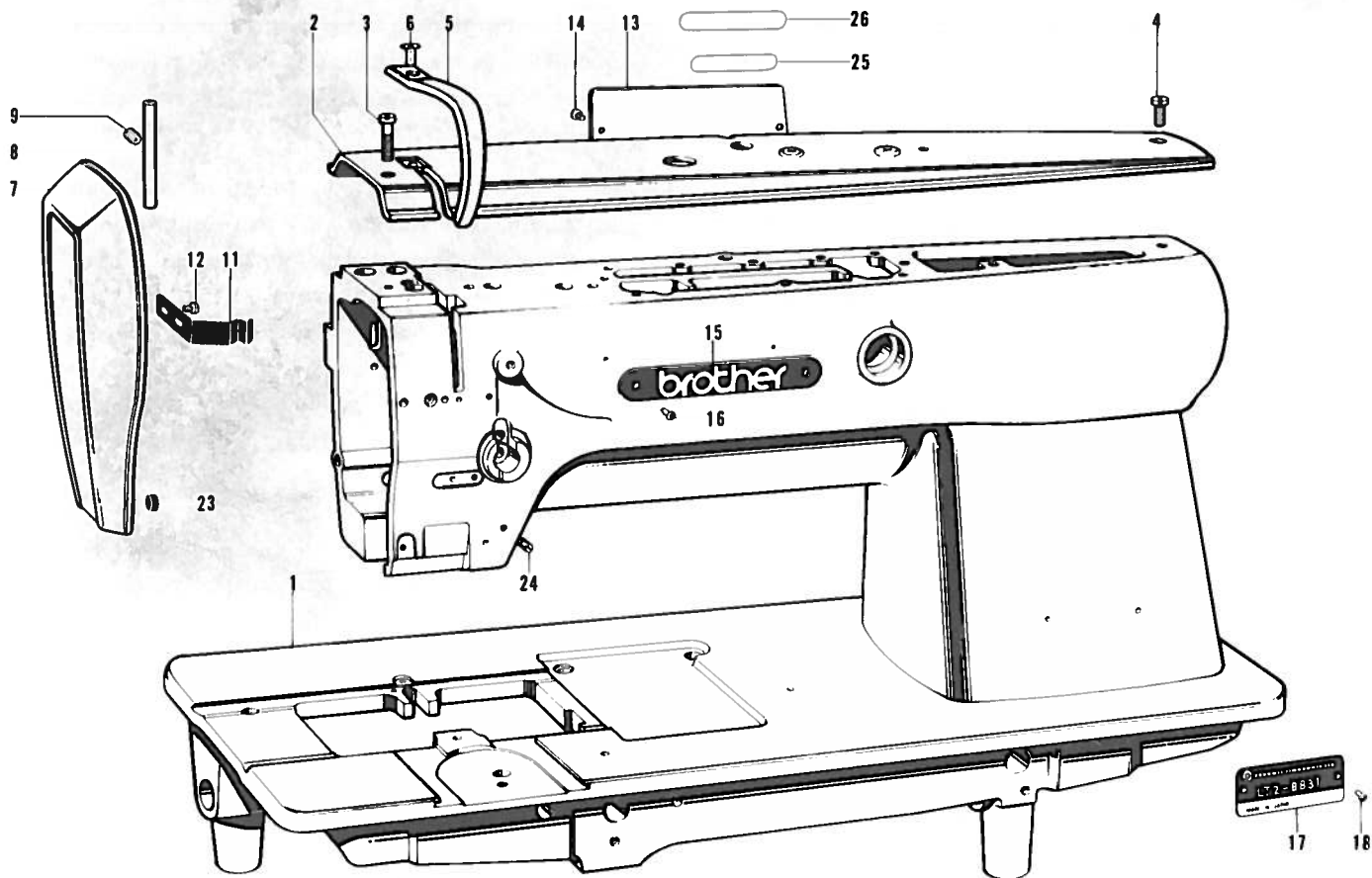

Ref. No.	Name of Parts	Q'ty	Parts No.	Assembly No.	Ref. No.	Name of Parts	Q'ty	Parts No.	Assembly No.
1	Arm Bed	1			13	Rear Cover	1	112566-003	
2	Arm Top Cover	1	112560-003		14	Screw 357 - 40 x 6	2	062670-612	
3	Screw 437 - 40 x 16	1	062681-612		15	Name Plate	1		
4	Screw 437 - 40 x 10	1	062681-012		16	Pin	2		
5	Thread Take-up Cover	1	112561-003		17	Model Plate	1		
6	Screw 4.76	1	107231-002		18	Pin	2		
7	Face Plate	1	112562-002		23	Cushion	1	114925-001	
8	Pin	1	112563-001		24	Screw 4.37	2	151602-002	
9	Screw 3.57	1	011679-312		25	Name Plate	1		
11	Spring	1	114924-001		26	Parts Book Number Plate	1		
12	Screw 357 - 40 x 5	2	062670-512						

B. Threading mechanism / Fadenführungsrichtung
Mécanisme de Jénfilage / Mécanisme de la enhebrado

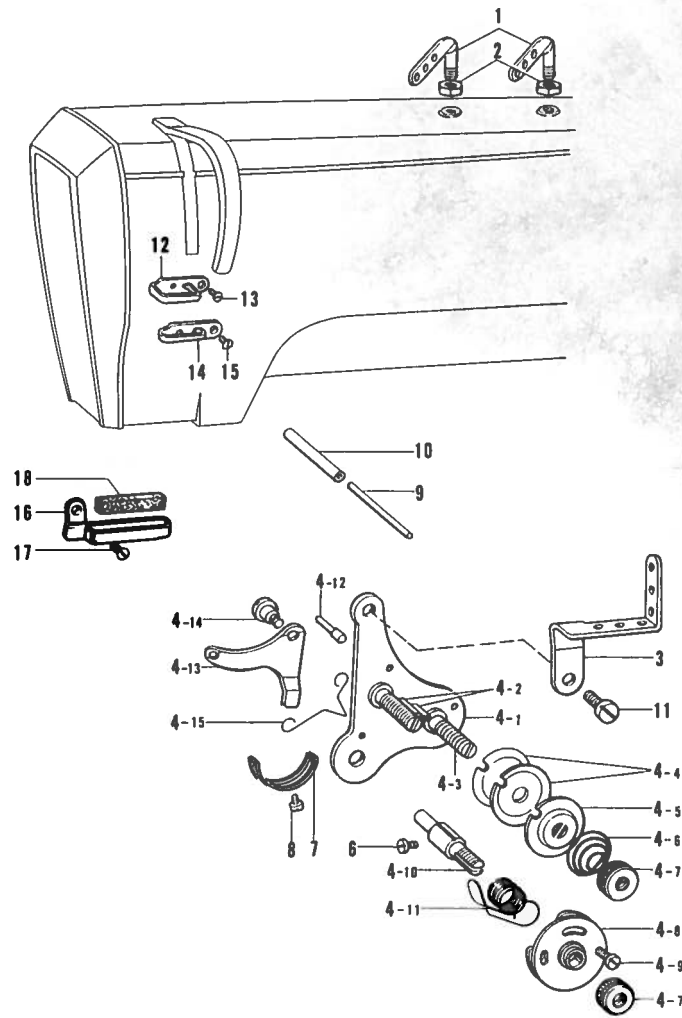

Ref. No.	Name of Parts	Q'ty	Parts No.	Assembly No.	Ref. No	Name of Parts	Q'ty	Parts No.	Assembly No.
1	Top Cover Therad Guide	2	140527-001		4-13	Tension Release Lever	1	112711-001	B-4
2	Nut 5.95	2	150553-003		4-14	Stud Screw 3.57	2	112712-001	
3	Thread Retainer	1	108056-001		4-15	Tension Release spring	1	118320-001	
4- 1	Under Thread Tension Plate	1		B-4 Tension Regulator Assembly (for-1, -3) 180231-001 (for-5) 148010-001	6	Screw 3.57	1	100064-002	
4- 2	Pin	2			7	Stopper	1	112709-001	
4- 3	Tension Stud	2			8	Screw 357 - 40 x 6	1	062670-612	
4- 4	Tension Disc	4	108263-001		9	Thread Tension Releaser	1	112713-001	
4- 5	Tension Disc Washer	2	108264-001		10	Pipe	1	112714-000	
4- 6	Tension Spring (for -1, -3)	2	118317-001		11	Screw 437 - 40 x 10	1	062681-012	
	Tension Spring (for-5)	2	148924-001		12	Arm Thread Guide (Upper)	1	108266-001	
4- 7	Tension Control Nut	3	108265-001		13	Screw 3.57	1	108960-002	
4- 8	Spring Guide Assembly	1	108254-001		14	Arm Thread Guide (Center)	1	112658-001	
4- 9	Screw 2.38	1	118319-001		15	Screw 3.57	1	108960-002	
4-10	Tension Stud	1			16	Arm Thread Guid (Lower)	1	112715-001	
4-11	Thread Take-up Spring	1	108262-001		17	Screw 3.57	1	108960-002	
4-12	Pin	2	112710-001	18	Felt	1	114941-001		

C. Upper shaft mechanism / Obere Welle
 Mécanisme de l'arbre supérieur / Mecanismo de la eje superior

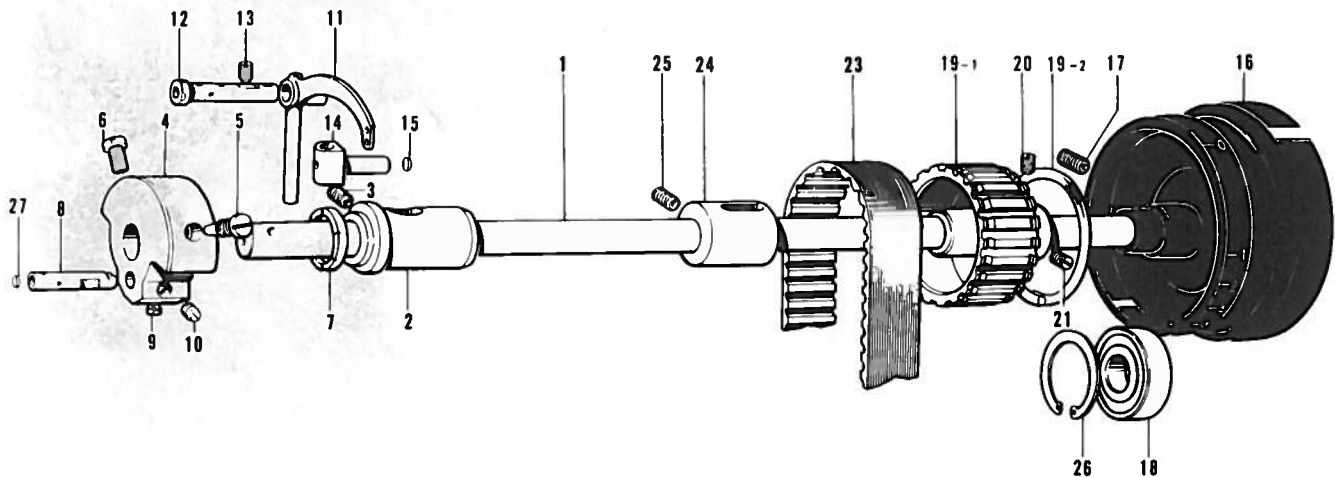

Ref. No.	Name of Parts	Q'ty	Parts No.	Assembly No.	Ref. No.	Name of Parts	Q'ty	Parts No.	Assembly No.
1	Upper Shaft	1	112572-001		16	Pulley	1	142112-001	
2	Upper Shaft Bushing (Left)	1	112573-001		17	Screw 5.95	2	013761-410	
3	Screw 5.95	1	013761-410		18	Bearing 6204	1	072620-460	
4	Counter Weight	1	112574-000		19- 1	Timing Belt Wheel (Upper)	1	/	C-19 Timing Belt Wheel (Upper) Assembly 180157-001
5	Screw 7.14	1	100250-001		19- 2	Timing Belt Wheel Ring	2		
6	Screw 7.14	1	146141-001		20	Screw 6.35 x 12	1	015771-212	
7	Thrust Ring	1	112576-001		21	Screw 6.35 x 12	1	013771-212	
8	Needle Bar Crank	1	112577-001		23	Timing Belt	1	112586-001	
9	Screw 6.35	1	101706-001		24	Upper Shaft Bushing (Center)	1	114680-001	
10	Screw 6.35	1	100251-001		25	Screw 5.95	1	013761-410	
11	Thread Take-up Lever (for - 1, - 3)	1	112578-001		26	Stop Ring C	1	112760-001	
	Thread Take-up Lever (for - 5)	1	140525-001		27	Pusher	1	113014-000	
12	Stud	1	112579-001						
13	Screw 5.95	1	013761-410						
14	Thread Take-up Lever Slide Block	1	118171-001						
15	Pusher	1	113024-000						

D. Feed shaft mechanism / Transport Welle
 Mécanisme de l'arbre entrainement / Mécanismo de la eje alimentación

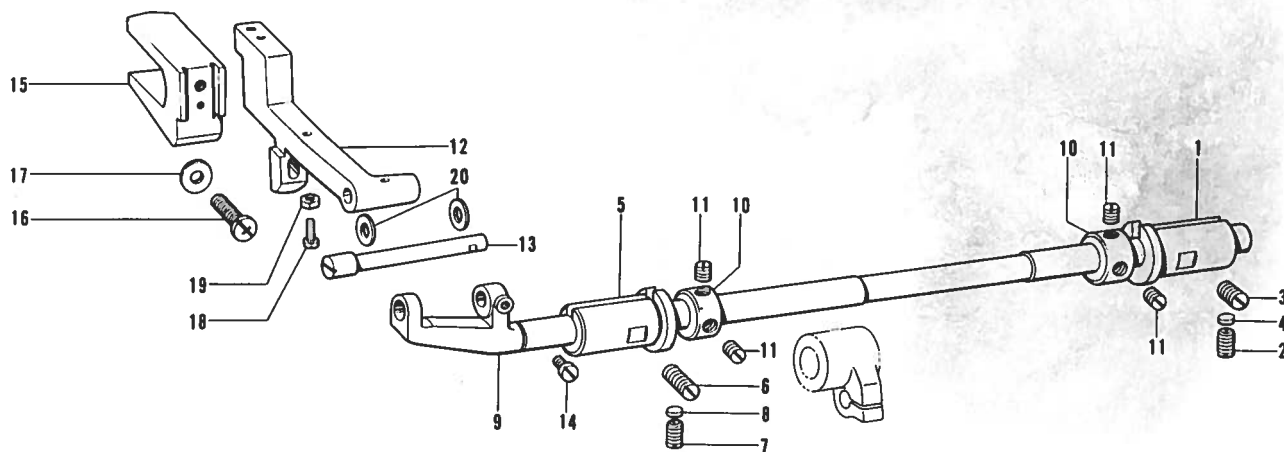

Ref. No.	Name of Parts	Q'ty	Parts No.	Assembly No.	Ref. No.	Name of Parts	Q'ty	Parts No.	Assembly No.
1	Feed Rock Shaft Bushing (Right)	1	112649-001		11	Screw 6.35	4	101706-001	
2	Screw 5.95	1	151604-001		12	Feed Bar	1	151081-001	
3	Screw 5.95	1	013761-410		13	Feed Bar Shaft	1	148977-001	
4	Washer	1	107793-000		14	Screw 4.37	1	104908-004	
5	Feed Rock Shaft Bushing (Left)	1	112650-001		15	Feed Bar Fork	1	112656-001	
6	Screw 5.95	1	013761-410		16	Screw 595 - 28 x 14	1	062761-412	
7	Screw 5.95	1	013761-410		17	Washer 6	1	025060-132	
8	Washer	1	107793-000		18	Screw 318 - 40 x 12	1	062661-212	
9	Feed Rock Shaft	1	149001-001		19	Nut 3.18	1	021660-102	
10	Collar	2	113074-001		20	Thrust Ring	2	143591-001	

F. Presser foot mechanism / Stoffdrückerfuß
 Mécanisme du pied presseur / Mecanismo del prensa telas

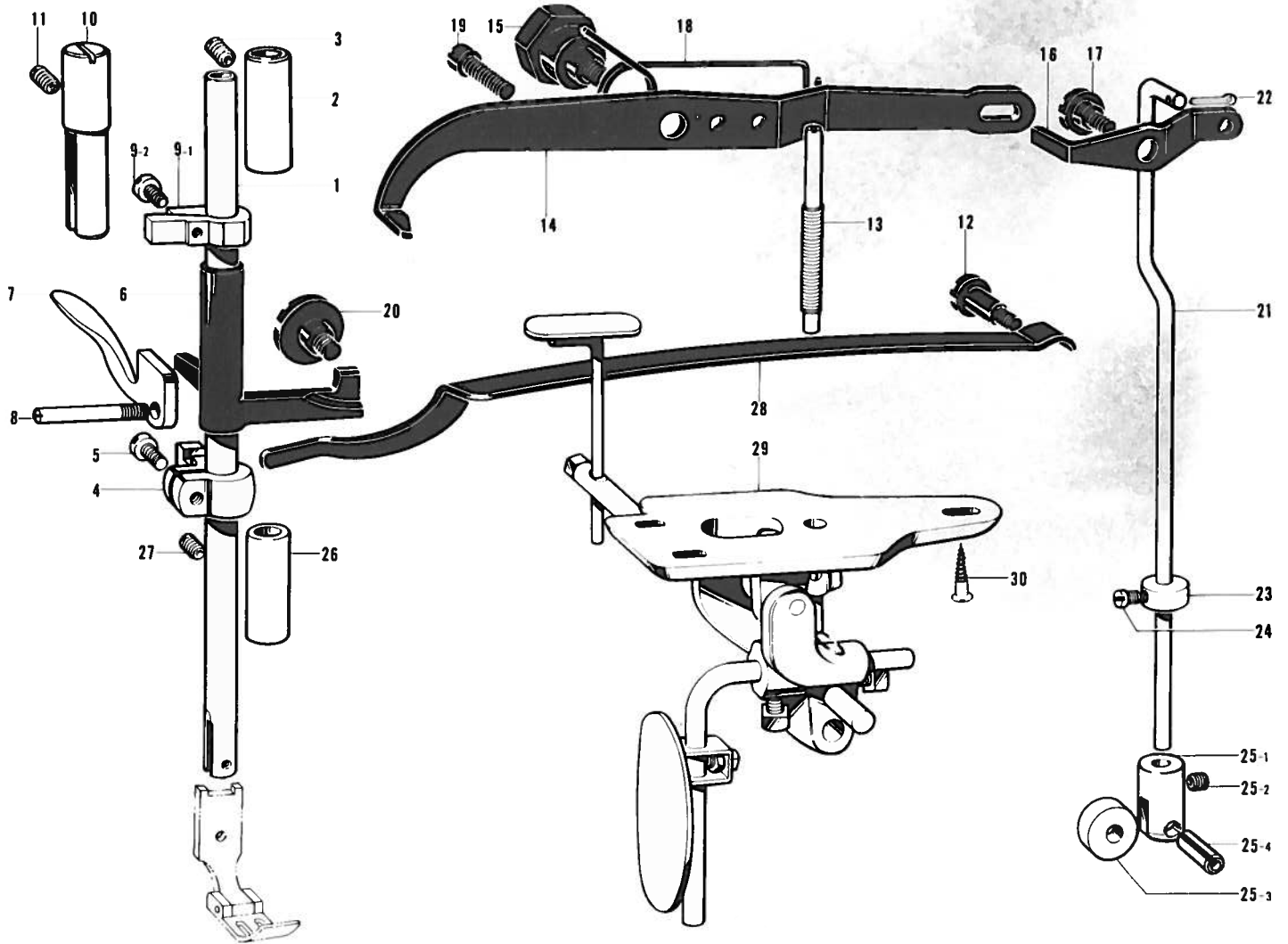

Ref. No.	Name of Parts	Q'ty	Parts No.	Assembly No.	Ref. No.	Name of Parts	Q'ty	Parts No.	Assembly No.
1	Presser Bar	1	112614-001		16	Knee Lifter Connecting Lever	1	155505-001	
2	Presser Bar Bushing (Upper)	1	112615-001		17	Stud Screw 6.35	1	112628-001	
3	Screw 5.95	1	013761-410		18	Spring	1	112629-001	
4	Presser Bar Bracket	1	112616-001		19	Stopper Screw	1	112630-001	
5	Screw 357 - 40 x 8	1	062670-812		20	Screw	1	112631-001	
6	Presser Bar Lifter	1	112617-001		21	Knee Lifter Connecting Rod	1	155447-101	
7	Presser Foot Lifter	1	112618-001		22	Pin	1	114909-000	
8	Screw	1	112619-001		23	Collar	1	159436-001	
9- 1	Presser Bar Guide	1		F-9 Presser Bar Guide Assembly 180950-001	24	Screw 4.37	1	104908-004	
9- 2	Screw 437 - 40 x 7	1	062680-712		25- 1	Roller Bracket	1		F-25 Knee Lifter Roller Assembly 156824-001
					25- 2	Screw 4.37	1	151601-002	
					25- 3	Roller	1	112636-001	
10	Presser Bar Guide Shaft	1	112621-001		25- 4	Spring Pin AW5	1	047501-242	
11	Screw 5.95	1	013761-410		26	Presser Bar Bushing (Lower)	1	112763-001	
12	Stud Screw 6.35	1	112623-001		27	Screw 5.95	1	151605-001	
13	Presser Adjusting Screw	1	112624-001		28	Presser Plate Spring	1	118170-101	
14	Knee Lifter Lever	1	112625-001		29	Knee Lifter Assembly	1	113380-001	
15	Stud Screw 6.35	1	112626-001		30	Screw 6.2 x 32	3	106030-001	

G. Gauge parts mechanism / Lehren
Pièces d'écartement / Piezas calibradoras

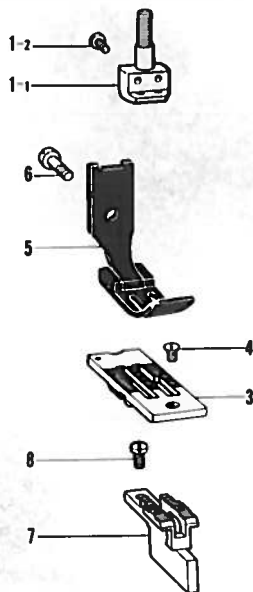

Ref. No.	Name of Parts	Q'ty	Parts No.	Assembly No.
1- 1	Needle Clamp	1		G-1 Needle Clamp With Screw ※
1- 2	Screw 3.57	2	116323-001	
3	Needle Plate	1	※	
4	Screw 4.37 (for - 1)	1	117160-001	
	Screw 4.37 (for - 3, - 5)	1	100032-004	
5	Presser Foot (Assembly)	1	※	
6	Screw 3.57	1	113050-001	
7	Feed Dog	1	※	
8	Screw 3.18	2	116283-001	

- If there is a "※" mark in the parts code column or assembly code column, refer to the gauge parts list.
- Falls in den kolonnen für Teilcode und Satzcode das Zeichen "※"steht, wird auf die Lehren liste auf verwiesen.
- Si le signe apparaît dans la colonne du code des pièces ou dans celle du code d'assemblage, se reporter à la liste des pièces de la jauge.
- Si aparece una marca "※" en la columna de código de piezas o en la columna de código de armado, consultar la lista de piezas calibradoras.

Gauge parts list / Lehren liste
Liste des pièces d'écartement / Lista de piezas calibradoras

Gauge Size Lehre Taille de jauge Tamaño de galga	Sub class Untergruppe Sous-classe Subclase	G-1 Needle Clamp Nadelklammer Pince-iguille Ménsula de aguja	G-3 Needle Plate Stichplatte Plateau à aiguille Placa de aguja	G-7 Feed Dog Transporteur Griffe d'entraînement Alimentador	G-5 Presser Foot Stoffdrückfuß Presseur Prensatelas	E-10 Slide Plate (Left) Deckel (Linke) Plaques de gissement (Gauche) Placas correderas (Izquierda)	
Tandem (0.5 mm)	-3	158801-001	142111-001	142110-001	142105-001	112606-001	
1/16 inch (1.6 mm)	-3	158808-001	142111-001	151078-001	151076-001		
1/8 inch (3.2 mm)	-1	158794-001	117370-001	117366-001	114948-001		
	-3		114950-001				
	-5		117369-001				
5/32 inch (4.0 mm)	-3	158796-001	116503-001	116509-001	116502-001		
	-5		150850-001				
3/16 inch (4.8 mm)	-1	158791-001	117158-001	117134-001	112638-001		
	-3		112603-001				
	-5		117133-001				
1/4 inch (6.4 mm)	-1	158792-001	117368-001	117365-001	112642-001		
	-3		112604-001				
	-5		117367-001				
5/16 inch (7.9 mm)	-3	158793-001	112605-001	112661-001	112645-001		
	-5		144882-001				
3/8 inch (9.5 mm)	-3	158798-001	116506-101	116510-101	116498-001		
	-5		144881-101				
7/16 inch (11.1 mm)	-3	158809-001	151596-001	151598-001	151597-001		
1/2 inch (12.7 mm)	-3	158797-001	116505-001	116511-001	116499-001		
5/8 inch (15.9 mm)	-5	158795-001	116507-001	116512-001	116500-001		
1 inch (25.4 mm)	-3	158805-001	147176-001	147178-001	147177-001		
1-1/4 inch (31.8 mm)	-3	158799-001	116504-001	116508-001	116501-001		
1-1/2 inch (38.1 mm)	-3	158800-001	118945-001	118947-001	118946-001		145721-001

G-5 Presser Foot with Guide / Stoffdrückerfuß mit Führung Pied presseur avec guide / Pie del prensatelas con guía	
1/8 inch (3.2 mm)	149311-001
3/16 inch (4.8 mm)	117281-001
1/4 inch (6.4 mm)	149312-001



H. Rotary hook mechanism / Greifervorrichtung
Mécanisme du crochet rotatif / Mécansmo cangrejo

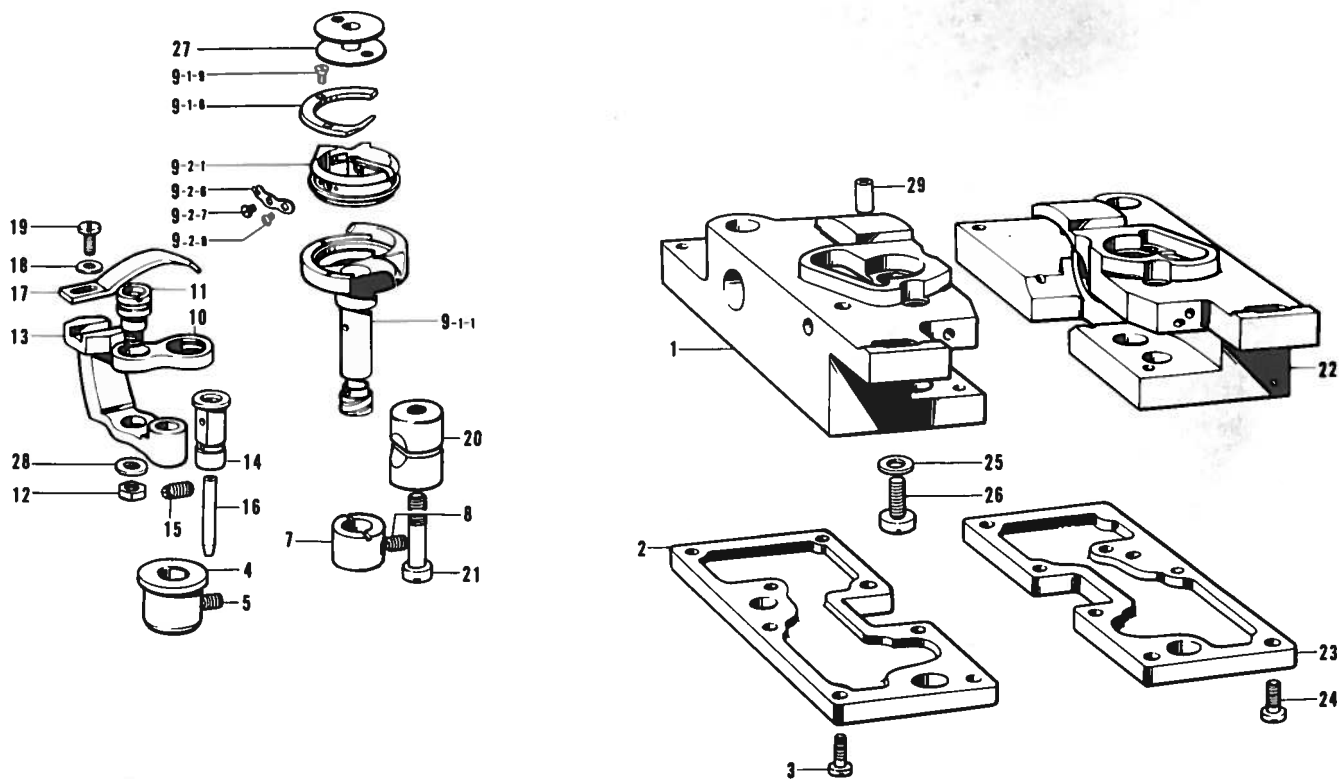

Ref. No.	Name of Parts	Q'ty	Parts No.	Assembly No.	Ref. No.	Name of Parts	Q'ty	Parts No.	Assembly No.
1	Rotary Hook Base (Left)	1	112685-001		10	Opener Link	2	112692-001	
2	Oil Reservoir (Left)	1	112686-001		11	Link Stud Opener	2	148005-001	
3	Screw 4.76	8	100320-002		12	Nut 4.76	2	110161-006	
4	Rotary Hook Shaft Bushing (Lower)	2	112687-001		13	Opener Crank	2	112694-001	
5	Screw 4.76	2	107794-001		14	Opener Crank Stud	2	112695-001	
7	Rotary Hook Shaft Bushing (Upper)	2	112690-001		15	Screw 4.76	2	153483-001	
8	Screw 4.76	2	107794-001		16	Pipe	1	112696-000	
9- 1- 1	Outer Rotary Hook	2		H-9-1 Outer Rotary Hook Assembly (for-1, -3) 151132-001 (for-5) 159931-001	17	Bobbin Case Opener	2	112697-001	
9- 1- 8	Inner Rotary Hook Presser	2			18	Washer	2	105161-002	
9- 1- 9	Screw	4	151027-001		19	Screw 357 - 40 x 8	2	062670-812	
9- 2- 1	Inner Rotary Hook	2		H-9 Rotary Hook Assembly (for-1, -3) 112691-001 (for-5) 144903-001	20	Pinch Sleeve	2	112699-001	
9- 2- 6	Tension Adjusting Spring (for - 1, - 3)	2	151145-001		21	Screw 5.95	2	112700-001	
	Tension Adjusting Spring (for - 5)	2	151146-001		22	Rotary Hook Base (Right)	1	112701-001	
9- 2- 7	Tension Adjusting Screw	2	151029-001		23	Rotary Hook Base Oil Reservoir (Right)	1	112702-001	
9- 2- 8	Screw	2	151030-001	H-9-2 Inner Rotary Hook Assembly (for-1, -3) 151138-001 (for-5) 151139-001	24	Screw 4.76	8	100320-002	
					25	Washer	2	100197-002	
					26	Screw 6.35	2	105351-002	
					27	Bobbin	2	112781-001	
					28	Washer 4.76	2	025710-232	
					29	Oil Pipe	2	115287-000	

J. Lower shaft mechanism / Untere Welle
Mécanisme de l'arbre inférieur / Mecanismo de la eje inferior

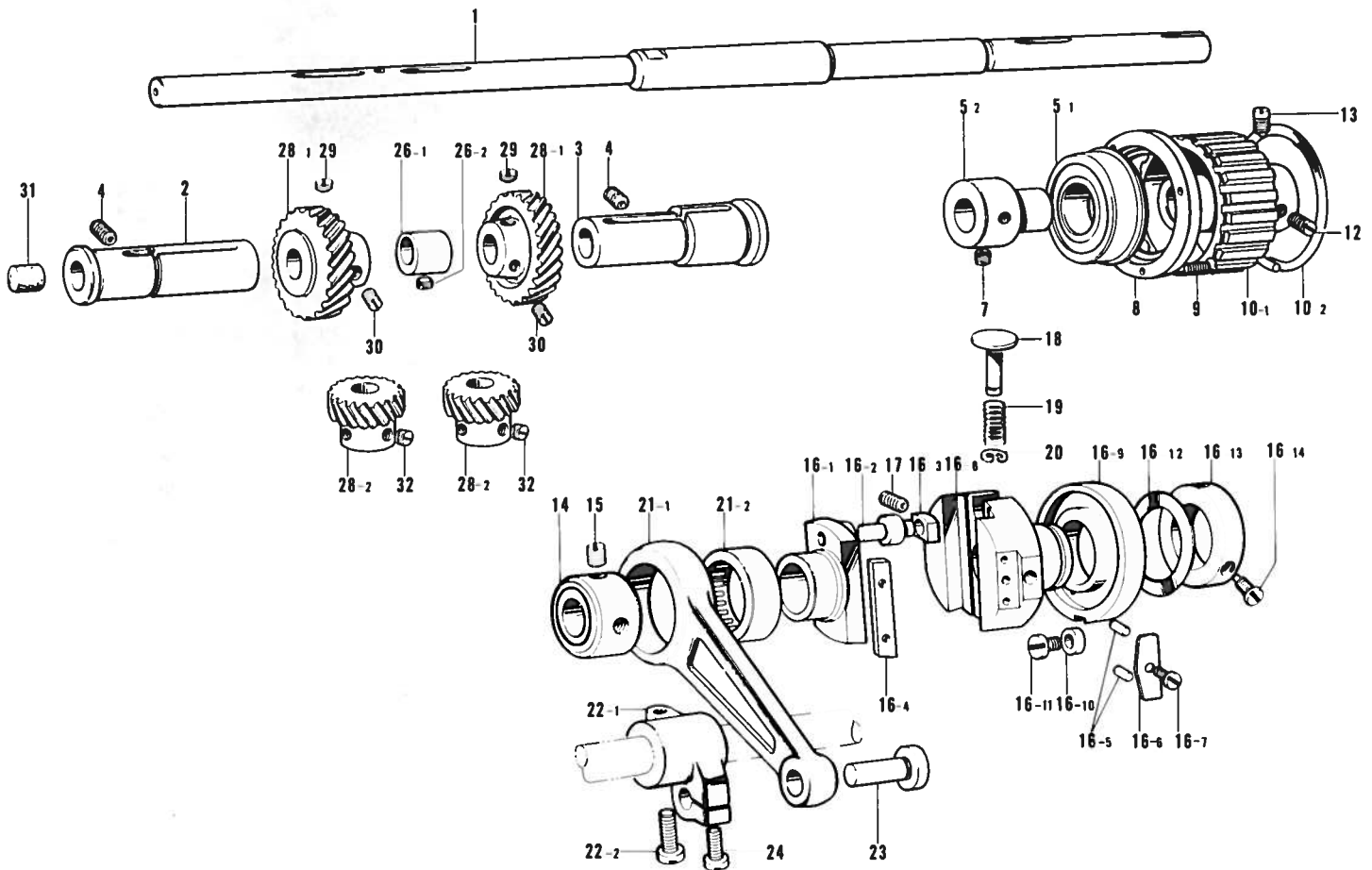

Ref. No.	Name of Parts	Q'ty	Parts No.	Assembly No.	Ref. No.	Name of Parts	Q'ty	Parts No.	Assembly No.
1	Lower Shaft	1	112663-001		16-11	Screw 3.18	2	101479-001	J-16
2	Rotary Hook Base Bushing (Left)	1	112664-000		16-12	Ripple Type Spring	1		
3	Rotary Hook Base Bushing (Right)	1	112665-000		16-13	Washer	1		
4	Screw 5.95	2	151605-001		16-14	Stop Ring C	1		
5- 1	Ball Bearing	1	112666-000	J-5 Bearing Holder Assembly 112698-001	17	Screw 5.95	2	013761-410	
5- 2	Bushing	1	112667-001		18	Feed Control Button	1	112677-001	
7	Screw 6.35 x 7	2	013780-710		19	Spring	1	103607-000	
8	Presser	1	112668-001		20	Stop Ring E4	1	048040-342	
9	Screw 3.57 x 12	3	005671-212		21- 1	Feed Connecting Rod	1	112678-000	J-21 Feed Connecting Rod Assembly 115262-001
10- 1	Timing Belt Wheel Lower	1		J-10 Timing Belt Wheel (Lower) Assembly 180164-001	21- 2	Needle Bearing	1	118954-000	
10- 2	Side Ring	1			22- 1	Feed Rock Shaft Arm	1		J-22 Feed Lifting Arm 180733-001
12	Screw 6.35 x 12	1	013771-212		22- 2	Screw 6.35 x 18	1	S01304-001	
13	Screw 6.35 x 12	1	015771-212		23	Stud	1	112681-001	
14	Thrust Collar	1	112672-001		24	Screw 437 - 40 x 12	1	062681-212	
15	Screw 5.95	2	151604-001		26- 1	Feed Eccentric	1		J-26 Feed Eccentric Assembly 181486-001
16- 1	Eccentric Wheel	1			26- 2	Screw 6.35	1	112684-001	
16- 2	Pin	1			28- 1	Spiral Gear	2		J-28 Spiral Gear Assembly 180949-001
16- 3	Slide Block	1			28- 2	Pinion	2		
16- 4	Gib	1		J-16 Eccentric Wheel Assembly (for-1, -3) 112673-001 (for-5) 149767-001	29	Screw 6.35	2	112684-001	
16- 5	Presser Pin	2			30	Screw 6.35	4	100251-001	
16- 6	Gib Stopper	1			31	Felt	1	115249-001	
16- 7	Screw 318 - 40 x 4	1	062660-412		32	Screw 6.35	6	101706-001	
16- 8	Eccentric Wheel Holder	1							
16- 9	Eccentric Feed Control Cam	1							
16-10	Cam Pitch Washer	2							

K. Lubrication (I) / Schmierung (I)
Lubrication (I) / Lubricación (I)

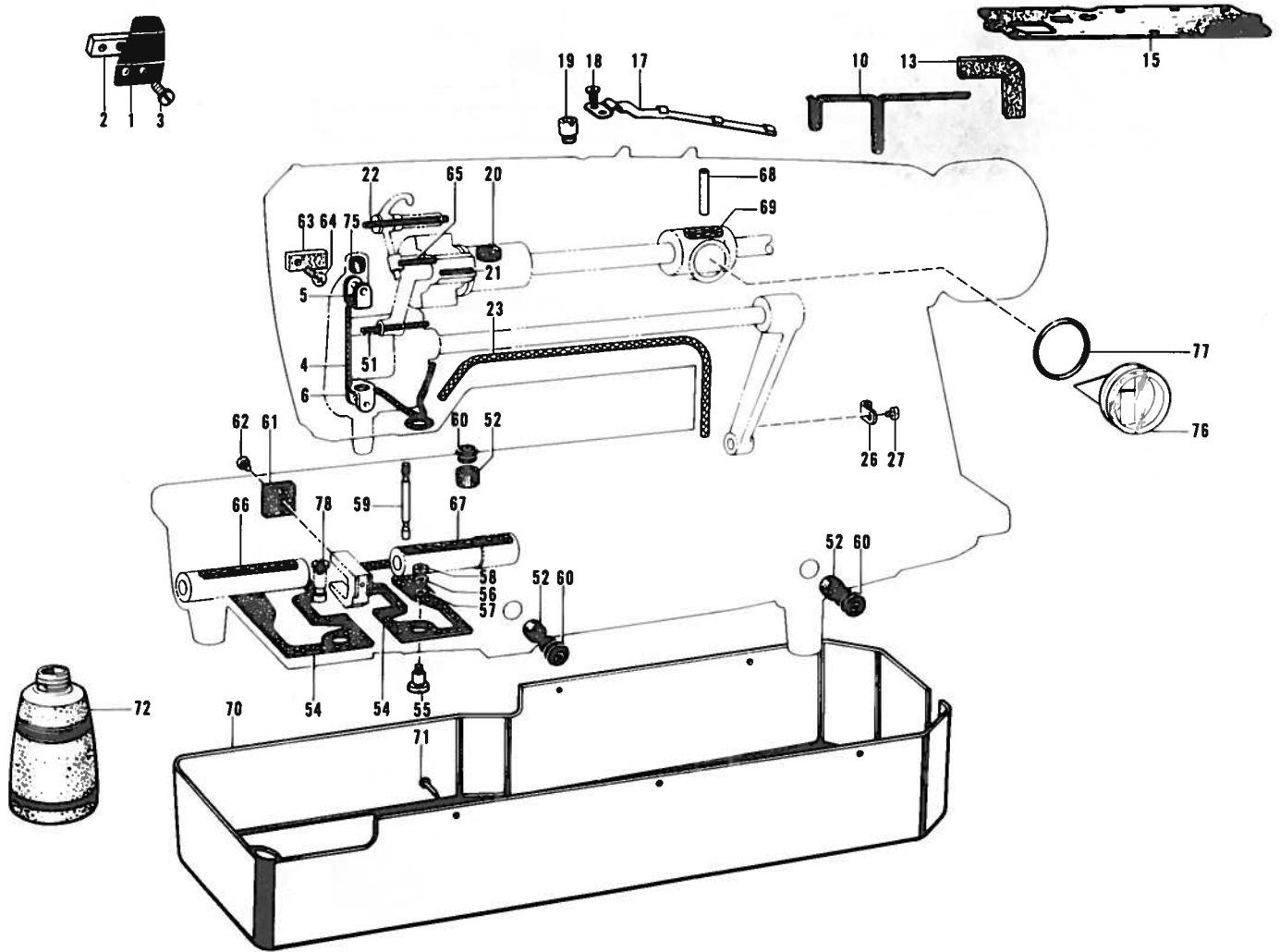

Ref. No.	Name of Parts	Q'ty	Parts No.	Assembly No.	Ref. No	Name of Parts	Q'ty	Parts No.	Assembly No.
1	Oil Stopper Plate	1	112716-001		56	Spring Washer 2 - 4.37	2	028680-242	
2	Oil Stopper Plate Presser	1	112717-001		57	Washer	2	100645-003	
3	Screw 476 - 32 x 8	1	062710-812		58	Nut 4.37	2	105234-003	
4	Wick (Ririan) 30 cm	1	116699-000		59	Oil Gauge	2	112757-001	
5	Wick Presser (Upper)	1	112719-001		60	Oil Cap	3	112758-001	
6	Wick Presser (Lower)	1	112720-001		61	Felt	1	112759-001	
10	Wick 4 x 4 (30 cm)	1	112725-001		62	Screw 3.57	1	100242-003	
13	Felt	1	112724-001		63	Felt	1	148762-001	
15	Packing	1	112723-001		64	Screw 357 - 40 x 6	1	060670-612	
17	Wick Holder	1	143657-001		65	Wick 3 x 3 (3 cm)	1	114693-001	
18	Screw 3.18	2	106640-001		66	Felt (Left)	1	113361-001	
19	Oil Tube Guide	1	113524-001		67	Felt (Right)	1	113362-001	
20	Felt	1	112734-001		68	Pipe	1	112696-000	
21	Wick 4 x 4 (9 cm)	1	112735-000		69	Felt	1	100248-001	
22	Wick 4 x 4 (6 cm)	1	112735-001		70	Oil Pan	1	151007-101	
23	Wick 4 x 4 (80 cm)	1	112736-000		71	Nail	5	109714-000	
26	Wick Supporter	1	112739-001		72	Oiler	1	114486-002	
27	Screw 357 - 40 x 5	1	062670-512		75	Needle Bar Cap	1	148394-000	
51	Wick 8 x 8 (4 cm)	1	112728-001		76	Oil Gauge Window	1	116558-001	
52	Felt	3	112753-001		77	Packing P16	1	081016-070	
54	Packing	2	112755-000		78	Felt	2	107155-001	
55	Oil Adjusting Screw	2	112756-001						

K. Lubrication (2) / Schmierung (2)
Lubrication (2) / Lubricación (2)

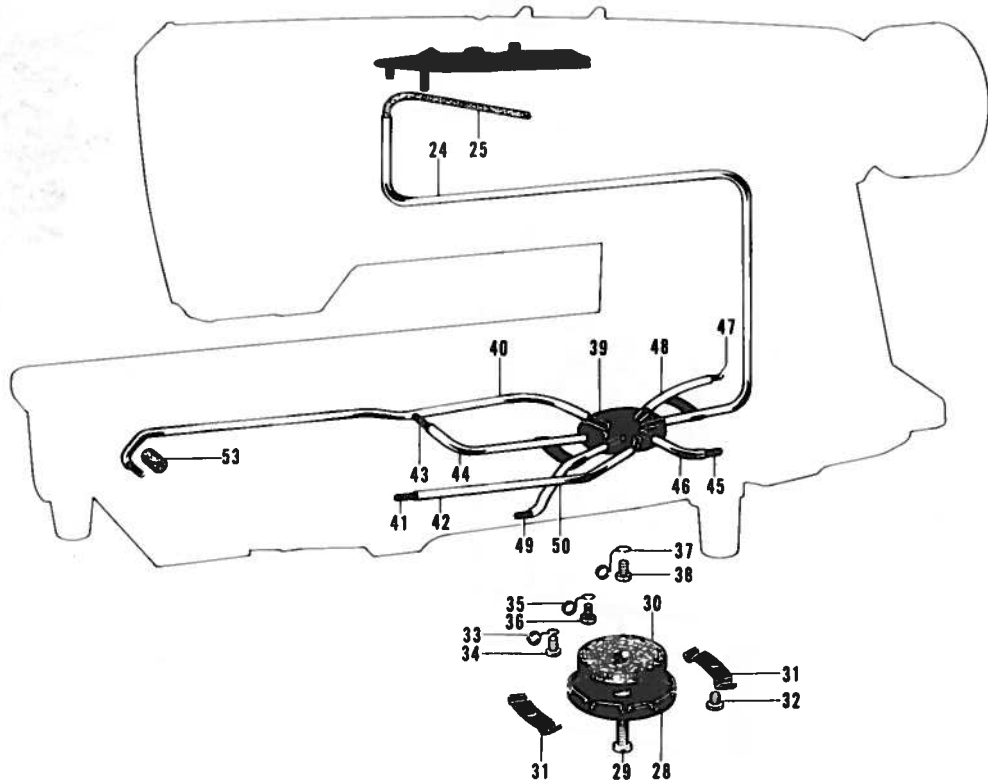
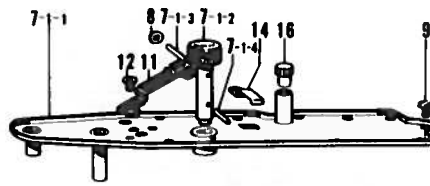
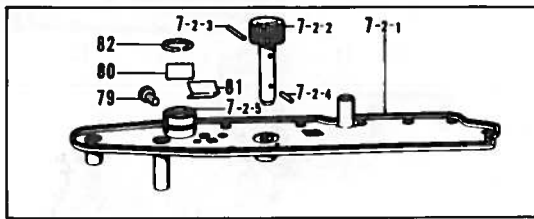

Ref. No.	Name of Parts	Q'ty	Parts No.	Assembly No.	Ref. No.	Name of Parts	Q'ty	Parts No.	Assembly No.
7- 1- 1	Oil Receiver Plate	1		K-7-1 Oil Receiver Plate Assembly (for-3, -5) 112762-001	33	Wick Holder	6	112743-001	
7- 1- 2	Oil Adjusting Knob	1			34	Screw 357 - 40 x 5	6	062670-512	
7- 1- 3	Pin	1			35	Tube Holder	3	112744-001	
7- 1- 4	Pin	1			36	Screw 357 - 40 x 5	3	062670-512	
7- 2- 1	Oil Plate	1			37	Wick Holder	1	112745-001	
7- 2- 2	Oil Adjusting Knob	1		K-7-2 Oil Pan Plate Assembly (for-1) 117200-001	38	Screw 357 - 40 x 5	1	062670-512	
7- 2- 3	Pin	1			39	Wick 4 x 4 (44 cm)	1	112746-000	
7- 2- 4	Pin	1			40	Oil Tube	1	112747-001	
7- 2- 5	Oil Plate Bushing	1			41	Wick 4 x 4 (36 cm)	1	112725-001	
8	Washer	1	503093-001		42	Oil Tube	1	112749-001	
9	Screw 357 - 40 x 6	10	062670-612	43	Wick 4 x 4 (19 cm)	1	112725-001		
11	Spring Plate	1	112730-001	44	Oil Tube	1	112749-001		
12	Screw 357 - 40 x 4	1	062670-412	45	Wick 3 x 3 (50 cm)	1	112750-000		
14	Felt Presser	1	114297-001	46	Oil Tube	1	143671-000		
16	Cap for Oil Inlet	1	113526-001	47	Wick 4 x 4 (11 cm)	1	112750-000		
24	Oil Tube	1	112737-001	48	Oil Tube	1	112669-001		
25	Wick 4 x 4 (72 cm)	1	112738-000	49	Wick 4 x 4 (45 cm)	1	112750-000		
28	Oil Tube Supporter	1	112740-001	50	Oil Tube	1	143671-000		
29	Screw 4.76	1	100320-002	53	Felt	1	112754-001		
30	Oil Felt	1	112741-001	79	Screw 357 - 40 x 10 (for -1)	1	062671-012		
31	Oil Tube Clamp	2	112742-001	80	Wick Stopper (for -1)	1	117203-001		
32	Screw 357 - 40 x 5	2	062670-512	81	Spring (for -1)	1	117204-001		
				82	Stop Ring (for -1)	1	117205-001		

Z. Accessories (1) / Zubehör (1)
Accessoires (1) / Accesorios (1)

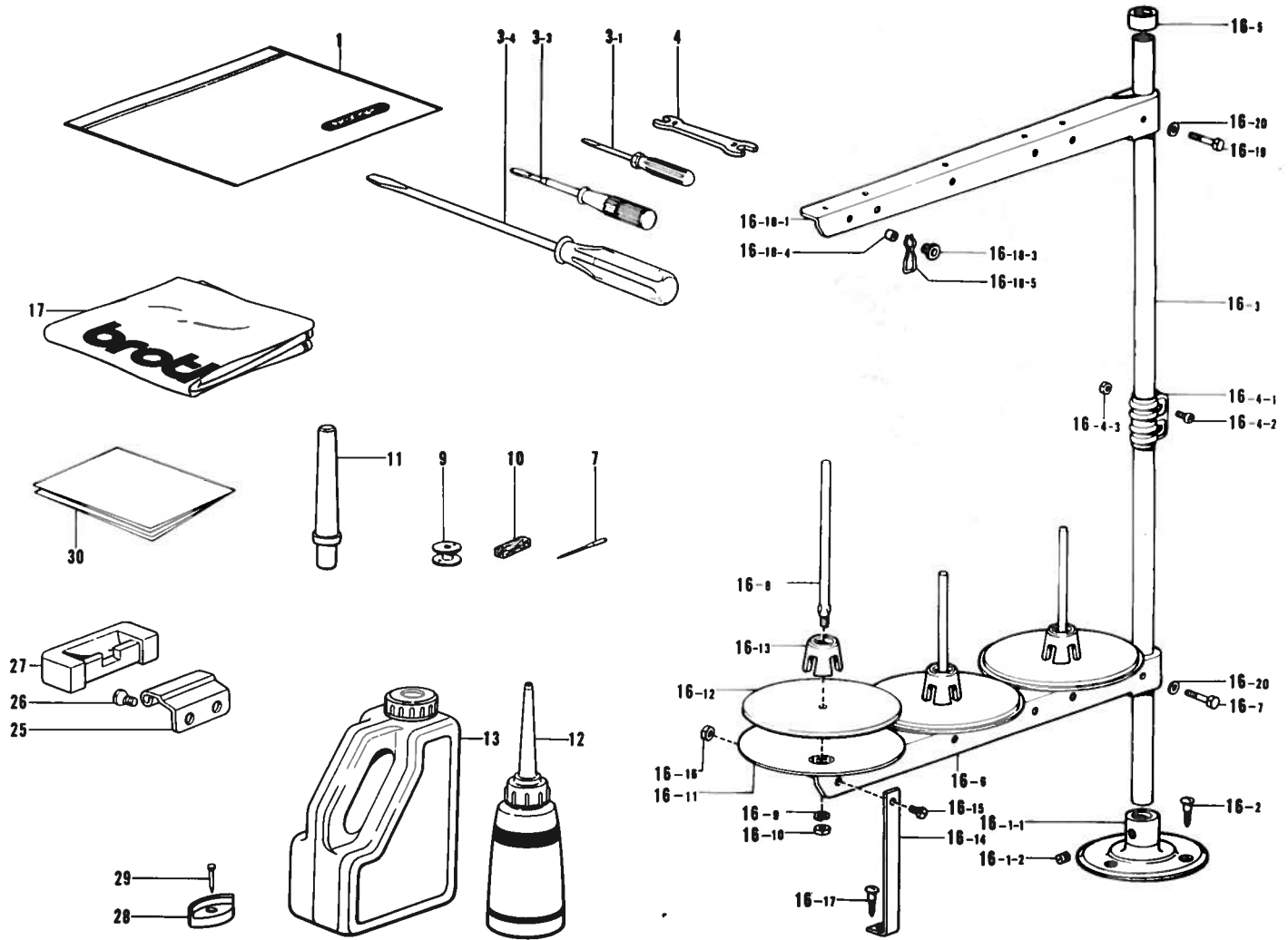

Ref. No.	Name of Parts	Q'ty	Parts No.	Assembly No.	Ref. No.	Name of Parts	Q'ty	Parts No.	Assembly No.
1	Vinyl Bag	1	122991-001		16- 6	Spool Holder	1	150176-001	Z-16 Cotton Stand Assembly 3 150151-003
3- 1	Screw Driver 1.9 x 52	1	142443-001		16- 7	Bolt 5 x 28	1	017502-803	
3- 3	Screw Driver 3.4 x 70	1	118837-001		16- 8	Spool Shaft (B)	3	150179-001	
3- 4	Screw Driver 5.5 x 190	1	101572-101		16- 9	Spring Washer 2 - 5	3	028050-243	
4	Spanner 8 x 9	1	100887-001		16-10	Nut 5	3	021500-103	
7	Needle DP x 5 #11 (for - 1)	8	107415-011		16-11	Spool Stand Base	3	150180-000	
	Needle DP x 5 #14 (for - 3)	8	107415-014		16-12	Spool Mat	3	150182-000	
	Needle DP x 5 #22 (for - 5)	8	107415-022		16-13	Spool Cushion	3	126863-000	
9	Bobbin	10	112781-001		16-14	Spool Holder Supporter (A)	1	150188-001	
10	Felt	2	114941-001		16-15	Screw 5 x 10	1	007501-003	
11	Head Rest	1	100477-001		16-16	Nut 5	1	021500-103	
12	Oiler	1	114483-002		16-17	Screw 4.5 x 22	1	031452-203	
13	Oil Tank	1	154702-001		16-18- 1	Spool Holder	1	150176-001	
16- 1- 1	Cotton Stand Base	1		Z-16-1 Cotton Stand Base Assembly 150139-001	16-18- 3	Thread Hanger	3		
16- 1- 2	Screw 6 x 7	2	150181-101		16-18- 4	Thread Bushing	3	142990-001	
16- 2	Screw 4.5 x 22	3	031452-203	Z-16 Cotton Stand Assembly 3 150151-003	16-18- 5	Thread Guide Spring	3	150184-001	
16- 3	Pipe	2	150172-001		16-19	Bolt 5 x 28	1	017502-803	
16- 4- 1	Joint	1		Z-16-4 Joint for Cotton Stand 150106-001	16-20	Washer 5	2	025050-233	
16- 4- 2	Screw 5 x 14	2	150202-001		17	Head Cover	1	144222-001	
16- 4- 3	Nut 5	2	021500-103		25	Head Hinge	2	148882-001	
16- 5	Cap	1			26	Screw 6.35	4	112569-001	
					27	Rubber Hinge	2	143910-001	
					28	Head Cushion	4	148890-101	
					29	Nail	8	109714-000	
					30	Table Sheet	1	150381-001	

*The details of included accessories are subject to change.
 *Änderungen in der Aufstellung der mitgelieferten Zubehöre sind vorbehalten.
 *Les détails des accessoires inclus sont sujets à des changements.
 *Los detalles de los accesorios incluidos pueden variar.

Z. Accessories (2) / Zubehör (2)
Accessoires (2) / Accesorios (2)

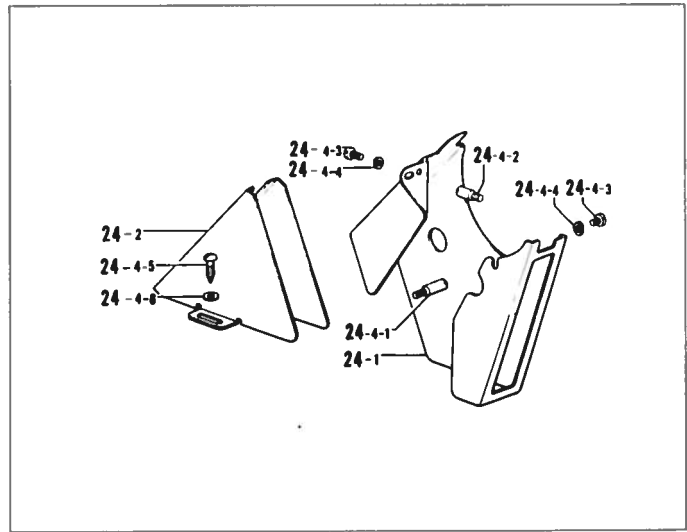
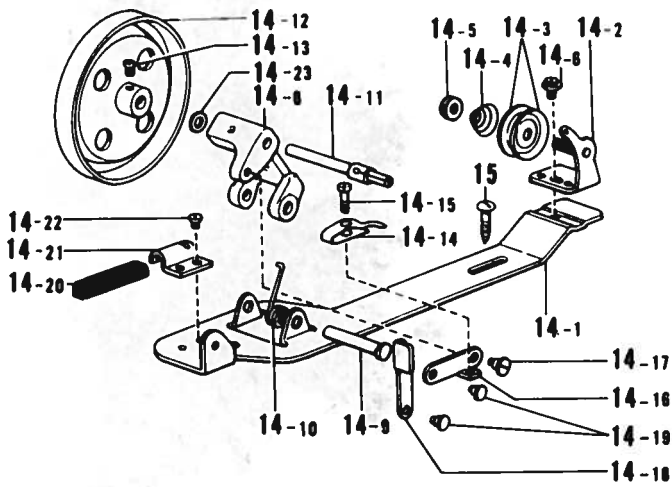

Ref. No.	Name of Parts	Q'ty	Parts No.	Assembly No.
14- 1	Bobbin Winder Wheel Bracket	1		Z-14 Bobbin Winder Assembly 117963-001
14- 2	Bobbin Winder Guide Assembly	1		
14- 3	Tension Disc	2	145446-001	
14- 4	Tension Spring	1	100401-001	
14- 5	Tension Control Nut	1	100136-002	
14- 6	Screw 4.37	1		
14- 8	Bobbin Winder Wheel Shaft Supporter	1		
14- 9	Pin	1		
14-10	Spring	1	117969-001	
14-11	Bobbin Winder Shaft	1	117970-001	
14-12	Bobbin Winder Wheel Assembly	1	117971-001	
14-13	Screw 4.37 x 5	1	100366-002	
14-14	Bobbin Presser	1	100656-001	
14-15	Screw 3.18	1	100657-001	
14-16	Bobbin Presser Arm	1		
14-17	Stud Screw 3.18	1	100659-001	
14-18	Bobbin Presser Bracket	1		
14-19	Pin	2		
14-20	Bobbin Winder Wheel Stopper	1	100662-001	
14-21	Bobbin Winder Wheel Stopper Holder	1		
14-22	Screw 3.57 x 3.5	1	S01297-001	
14-23	Washer	2		
15	Screw 5.5 x 20	2	100666-002	

Option Parts

Ref. No.	Name of Parts	Q'ty	Parts No.	Assembly No.
24- 1	Belt Cover (UD)	1		Z-24 Belt Cover Complete (D) 147908-001
24- 2	Belt Cover (D)	1		
24- 4- 1	Belt Cover Stud (B)	1	147856-002	
24- 4- 2	Belt Cover Stud (D)	1	147858-001	
24- 4- 3	Screw 437 - 40 x 8	2	062680-812	
24- 4- 4	Spring Washer 2 - 4.37	2	028680-242	
24- 4- 5	Screw 5.5 x 20	2	100666-002	
24- 4- 6	Washer 5.56	2	025750-132	

*The details of included accessories are subject to change.

*Änderungen in der Aufstellung der mitgelieferten Zubehöre sind vorbehalten.

*Les détails des accessoires inclus sont sujets à des changements.

*Los detalles de los accesorios incluidos pueden variar.

INDEX / VERZEICHNIS
INDEX / INDICE

Parts No.	Ref No.	Remark	Parts No.	Ref No.	Remark	Parts No.	Ref No.	Remark	Parts No.	Ref No.	Remark
S01297-001	Z- 14-22		062710-812	K- 3		108265-001	B- 4- 7		112660-001	G- 7	
S01304-001	E- 9		062761-412	D- 16		108266-001	B- 12		112661-001	G- 7	
	J- 22- 2		072620-460	C- 18		108960-002	B- 13		112663-001	J- 1	
005671-212	J- 9		081016-070	K- 77			B- 15		112664-000	J- 2	
007501-003	Z- 16-15		100032-004	G- 4		B- 17		112665-000	J- 3		
011679-312	A- 9		100064-002	B- 6		109714-000	K- 71		112666-000	J- 5- 1	
013761-410	C- 3		100136-002	Z- 14- 5			Z- 29		112667-001	J- 5- 2	
	C- 13		100197-002	H- 25		110161-006	H- 12	112668-001	J- 8		
	C- 17		100242-003	K- 62		112560-003	A- 2	112669-001	K- 48		
	C- 25		100248-001	K- 69		112561-003	A- 5	112672-001	J- 14		
	D- 3		100250-001	C- 5		112562-002	A- 7	112673-001	J- 16		
	D- 6		100251-001	C- 10		112563-001	A- 8	112677-001	J- 18		
	D- 7			J- 30		112566-003	A- 13	112678-000	J- 21- 1		
	F- 3		100320-002	H- 3		112569-001	Z- 26	112681-001	J- 23		
	F- 11			H- 24		112572-001	C- 1	112684-001	J- 26- 2		
	J- 17			K- 29		112573-001	C- 2		J- 29		
	013771-212	C- 21		100366-002	Z- 14-13		112574-000	C- 4	112685-001	H- 1	
		J- 12		100401-001	Z- 14- 4		112576-001	C- 7	112686-001	H- 2	
	013780-710	J- 7		100477-001	Z- 11		112577-001	C- 8	112687-001	H- 4	
015771-212	C- 20		100645-003	K- 57		112578-001	C- 11	112690-001	H- 7		
	J- 13		100656-001	Z- 14-14		112579-001	C- 12	112691-001	H- 9		
017502-803	Z- 16- 7		100657-001	Z- 14-15		112586-001	C- 23	112692-001	H- 10		
	Z- 16-19		100659-001	Z- 14-17		112589-100	E- 1- 2	112694-001	H- 13		
021500-103	Z- 16- 4- 3		100662-001	Z- 14-20		112590-001	E- 1- 4	112695-001	H- 14		
	Z- 16-10		100666-002	Z- 15		112592-001	E- 1- 7	112696-000	H- 16		
	Z- 16-16			Z- 24- 4- 5		112593-001	E- 1- 9		K- 68		
021660-102	D- 19		100887-001	Z- 4		112594-001	E- 2	112697-001	H- 17		
025050-233	Z- 16-20		101268-002	E- 7		112595-000	E- 3	112698-001	J- 5		
025060-132	D- 17		101479-001	J- 16-11		112596-001	E- 5	112699-001	H- 20		
025710-232	H- 28		101572-101	Z- 3- 4		112597-001	E- 6	112700-001	H- 21		
025750-132	Z- 24- 4- 6		101706-001	C- 9		112598-001	E- 8	112701-001	H- 22		
028050-243	Z- 16- 9			D- 11		112603-001	G- 3	112702-001	H- 23		
028680-242	K- 56			J- 32		112604-001	G- 3	112709-001	B- 7		
	Z- 24- 4- 4		102731-004	E- 1- 5		112605-001	G- 3	112710-001	B- 4-12		
031452-203	Z- 16- 2		103607-000	J- 19		112606-001	E- 10	112711-001	B- 4-13		
	Z- 16-17		104908-004	D- 14		112607-001	E- 11	112712-001	B- 4-14		
047501-242	F- 25- 4			F- 24		112610-001	E- 14	112713-001	B- 9		
048040-342	J- 20		105161-002	H- 18		112614-001	F- 1	112714-000	B- 10		
060670-612	K- 64		105234-003	K- 58		112615-001	F- 2	112715-001	B- 16		
062660-412	J- 16- 7		105351-002	E- 4		112616-001	F- 4	112716-001	K- 1		
062661-212	D- 18			H- 26		112617-001	F- 6	112717-001	K- 2		
062670-412	K- 12		106030-001	F- 30		112618-001	F- 7	112719-001	K- 5		
062670-512	A- 12		106640-001	K- 18		112619-001	F- 8	112720-001	K- 6		
	K- 27		107030-001	E- 1- 3		112621-001	F- 10	112721-001	E- 1-10		
	K- 32		107155-001	K- 78		112623-001	F- 12	112723-001	K- 15		
	K- 34		107231-002	A- 6		112624-001	F- 13	112724-001	K- 13		
	K- 36		107415-011	E- 16		112625-001	F- 14	112725-001	K- 10		
	K- 38			Z- 7		112626-001	F- 15		K- 41		
062670-612	A- 14		107415-014	E- 16		112628-001	F- 17		K- 43		
	B- 8			Z- 7		112629-001	F- 18	112728-001	K- 51		
	K- 9		107415-022	E- 16		112630-001	F- 19	112730-001	K- 11		
062670-812	E- 1- 8			Z- 7		112631-001	F- 20	112734-001	K- 20		
	F- 5		107793-000	D- 4		112636-001	F- 25- 3	112735-000	K- 21		
	H- 19			D- 8		112638-001	G- 5	112735-001	K- 22		
062671-012	K- 79		107794-001	H- 5		112642-001	G- 5	112736-000	K- 23		
062680-712	F- 9- 2			H- 8		112645-001	G- 5	112737-001	K- 24		
062680-812	Z- 24- 4- 3		108056-001	B- 3		112649-001	D- 1	112738-000	K- 25		
062681-012	A- 4		108254-001	B- 4- 8		112650-001	D- 5	112739-001	K- 26		
	B- 11		108262-001	B- 4-11		112656-001	D- 15	112740-001	K- 28		
062681-212	J- 24		108263-001	B- 4- 4		112658-001	B- 14	112741-001	K- 30		
062681-612	A- 3		108264-001	B- 4- 5		112659-001	G- 7	112742-001	K- 31		

Parts No.	Ref No.	Remark	Parts No.	Ref No.	Remark	Parts No.	Ref No.	Remark	Parts No.	Ref No.	Remark
112743-001	K- 33		116506-101	G- 3		147176-001	G- 3		155447-101	F- 21	
112744-001	K- 35		116507-001	G- 3		147177-001	G- 5		155505-001	F- 16	
112745-001	K- 37		116508-001	G- 7		147178-001	G- 7		156824-001	F- 25	
112746-000	K- 39		116509-001	G- 7		147856-002	Z- 24- 4- 1		158791-001	G- 1	
112747-001	K- 40		116510-101	G- 7		147858-001	Z- 24- 4- 2		158792-001	G- 1	
112749-001	K- 42		116511-001	G- 7		147908-001	Z- 24		158793-001	G- 1	
	K- 44		116512-001	G- 7		148005-001	H- 11		158794-001	G- 1	
112750-000	K- 45		116558-001	K- 76		148010-001	B- 4		158795-001	G- 1	
	K- 47		116699-000	K- 4		148394-000	K- 75		158796-001	G- 1	
	K- 49		117133-001	G- 3		148762-001	K- 63		158797-001	G- 1	
112751-003	E- 17		117134-001	G- 7		148882-001	Z- 25		158798-001	G- 1	
112753-001	K- 52		117158-001	G- 3		148890-101	Z- 28		158799-001	G- 1	
112754-001	K- 53		117160-001	G- 4		148924-001	B- 4- 6		158800-001	G- 1	
112755-000	K- 54		117200-001	K- 7- 2		148977-001	D- 13		158801-001	G- 1	
112756-001	K- 55		117203-001	K- 80		149001-001	D- 9		158805-001	G- 1	
112757-001	K- 59		117204-001	K- 81		149177-001	E- 26		158808-001	G- 1	
112758-001	K- 60		117205-001	K- 82		149311-001	G- 5		158809-001	G- 1	
112759-001	K- 61		117281-001	G- 5		149312-001	G- 5		159359-001	E- 1	
112760-001	C- 26		117365-001	G- 7		149767-001	J- 16		159360-001	E- 1- 6	
112762-001	K- 7- 1		117366-001	G- 7		150106-001	Z- 16- 4		159436-001	F- 23	
112763-001	F- 26		117367-001	G- 3		150139-001	Z- 16- 1		159931-001	H- 9- 1	
112764-001	E- 18		117368-001	G- 3		150151-003	Z- 16		180157-001	C- 19	
112781-001	H- 27		117369-001	G- 3		150172-001	Z- 16- 3		180164-001	J- 10	
	Z- 9		117370-001	G- 3		150176-001	Z- 16- 6		180231-001	B- 4	
113014-000	C- 27		117963-001	Z- 14			Z- 16-18- 1		180733-001	J- 22	
113024-000	C- 15		117969-001	Z- 14-10		150179-001	Z- 16- 8		180949-001	J- 28	
113050-001	G- 6		117970-001	Z- 14-11		150180-000	Z- 16-11		180950-001	F- 9	
113074-001	D- 10		117971-001	Z- 14-12		150181-101	Z- 16- 1- 2		181486-001	J- 26	
113361-001	K- 66		118170-101	F- 28		150182-000	Z- 16-12		503093-001	K- 8	
113362-001	K- 67		118171-001	C- 14		150184-001	Z- 16-18- 5				
113380-001	F- 29		118317-001	B- 4- 6		150188-001	Z- 16-14				
113386-000	E- 19		118319-001	B- 4- 9		150193-003	Z- 16-18				
113524-001	K- 19		118320-001	B- 4-15		150202-001	Z- 16- 4- 2				
113526-001	K- 16		118837-001	Z- 3- 3		150381-001	Z- 30				
114297-001	K- 14		118945-003	G- 3		150553-003	B- 2				
114483-002	Z- 12		118946-001	G- 5		150850-001	G- 3				
114486-002	K- 72		118947-001	G- 7		150917-001	E- 25				
114680-001	C- 24		118954-000	J- 21- 2		151007-101	K- 70				
114693-001	K- 65		122991-001	Z- 1		151027-001	H- 9- 1- 9				
114909-000	F- 22		126863-000	Z- 16-13		151029-001	H- 9- 2- 7				
114924-001	A- 11		140525-001	C- 11		151030-001	H- 9- 2- 8				
114925-001	A- 23		140527-001	B- 1		151076-001	G- 5				
114941-001	B- 18		142105-001	G- 5		151078-001	G- 7				
	Z- 10		142110-001	G- 7		151081-001	D- 12				
114948-001	G- 5		142111-001	G- 3		151132-001	H- 9- 1				
114950-001	G- 3		142112-001	C- 16		151138-001	H- 9- 2				
114951-001	G- 7		142443-001	Z- 3- 1		151139-001	H- 9- 2				
115249-001	J- 31		142990-001	Z- 16-18- 4		151145-001	H- 9- 2- 6				
115262-001	J- 21		143591-001	D- 20		151146-001	H- 9- 2- 6				
115287-000	H- 29		143657-001	K- 17		151191-001	E- 23				
116010-001	E- 15		143671-000	K- 46		151596-001	G- 3				
116283-001	G- 8			K- 50		151597-001	G- 5				
116323-001	G- 1- 2		143910-001	Z- 27		151598-001	G- 7				
116498-001	G- 5		144222-001	Z- 17		151601-002	F- 25- 2				
116499-001	G- 5		144458-001	E- 24		151602-002	A- 24				
116500-001	G- 5		144881-101	G- 3		151604-001	D- 2				
116501-001	G- 5		144882-001	G- 3			J- 15				
116502-001	G- 5		144903-001	H- 9		151605-001	F- 27				
116503-001	G- 3		145446-001	Z- 14- 3			J- 4				
116504-001	G- 3		145721-001	E- 10		153483-001	H- 15				
116505-001	G- 3		146141-001	C- 6		154702-001	Z- 13				

From the library of: Diamond Needle Corp

118-831
195831-302
1983,12